

ATE SERIES

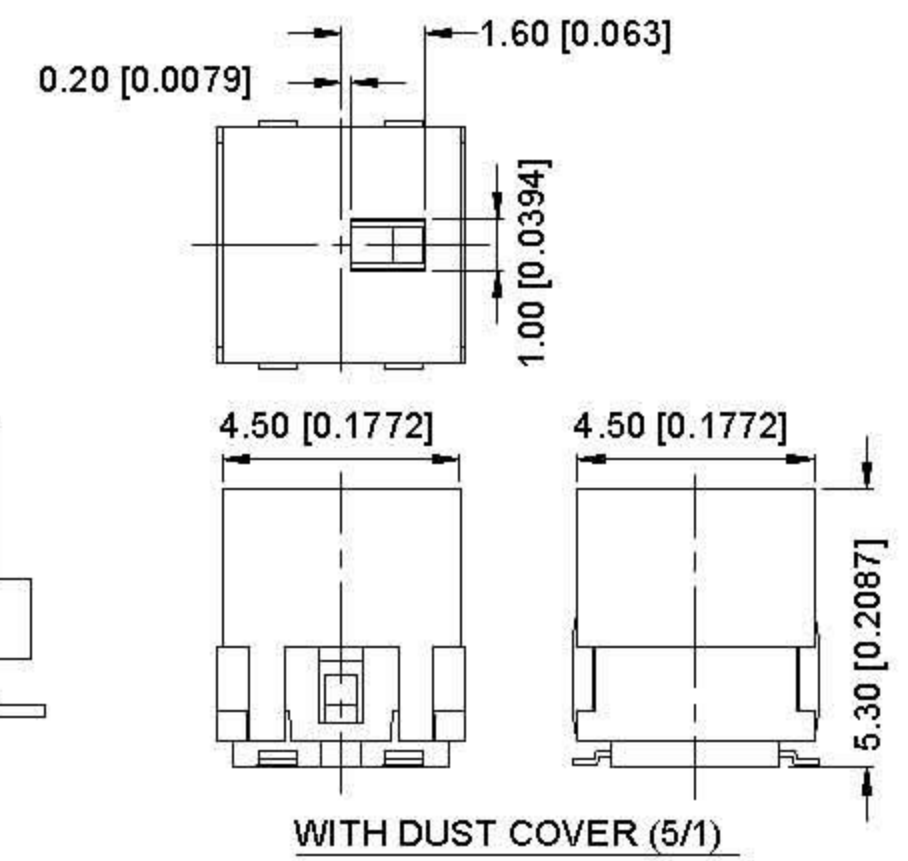

DIMENSIONS

ATE-1 □

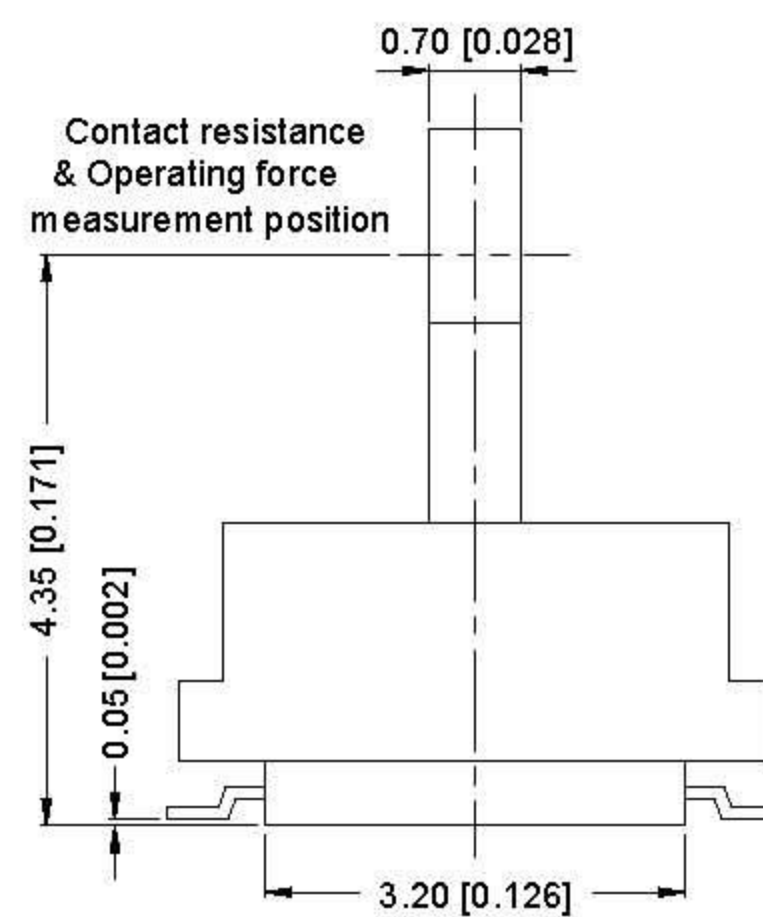
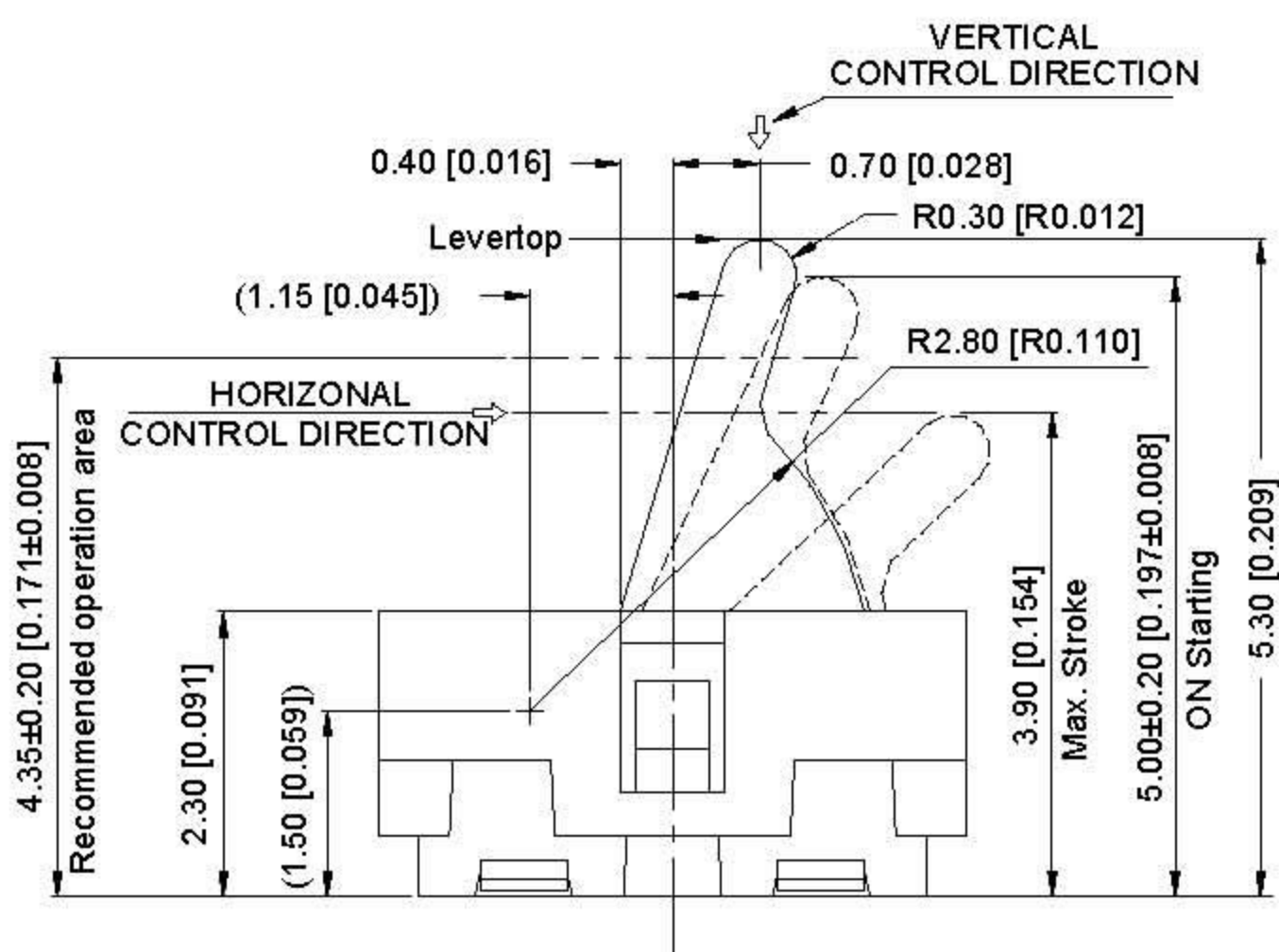
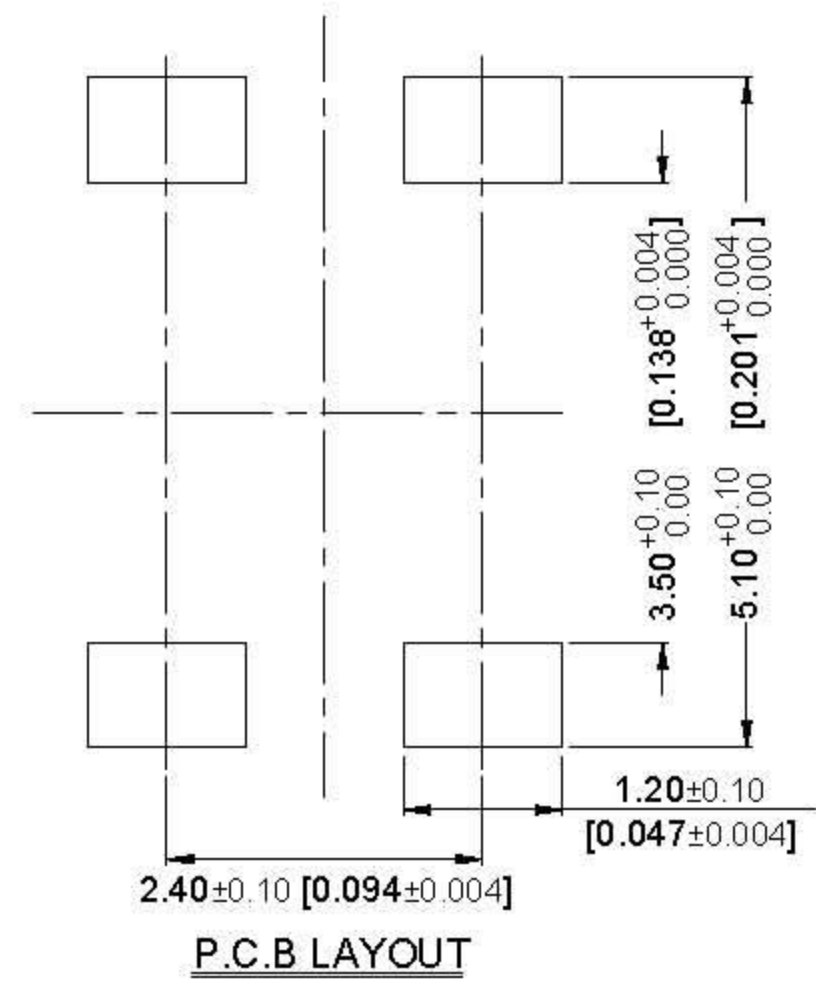
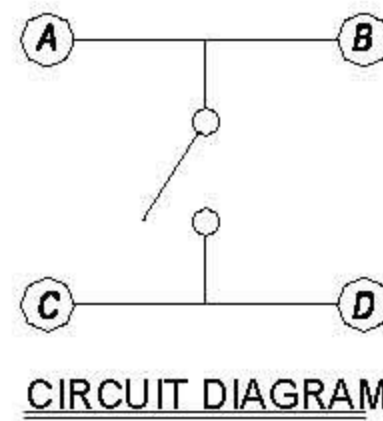
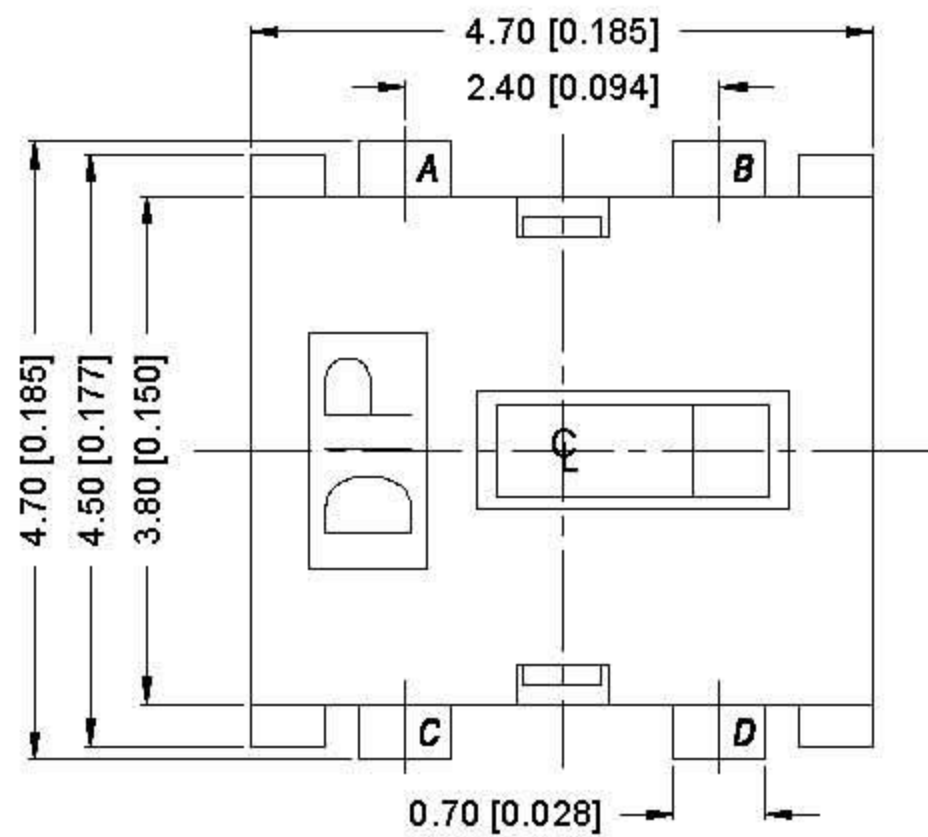

General Tolerance : ±0.2mm

ATE-2 □

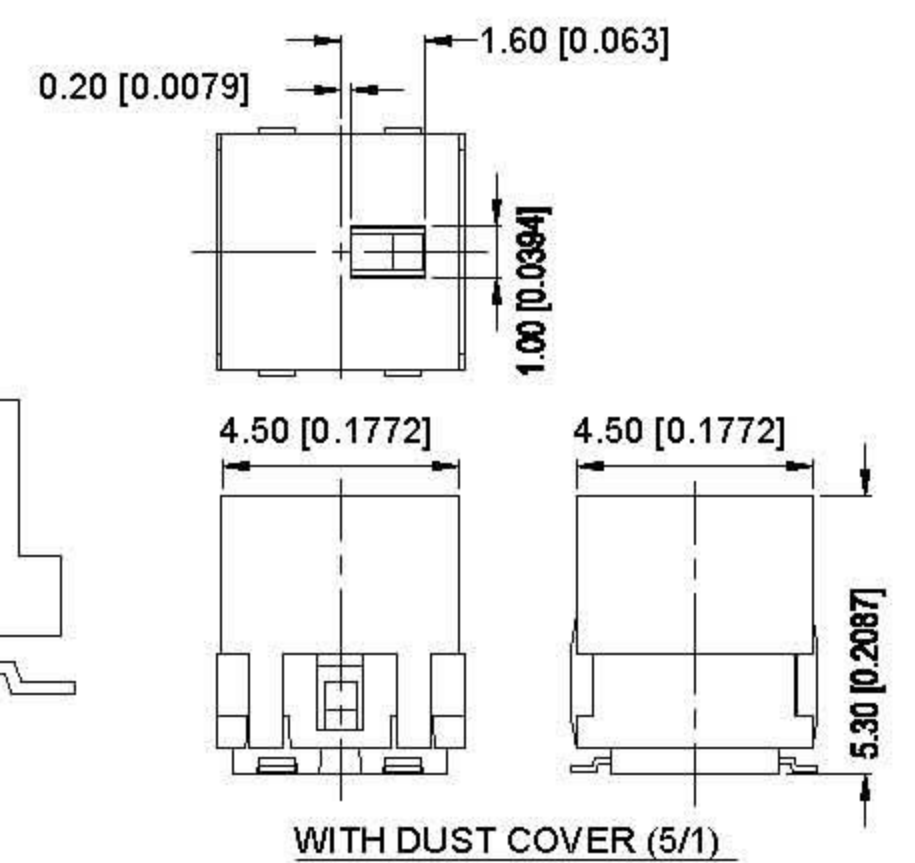
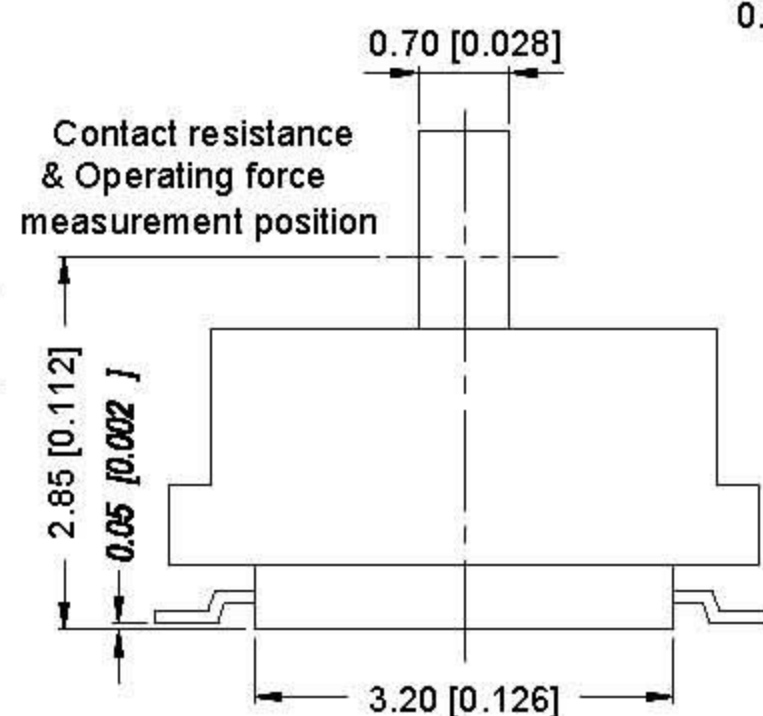
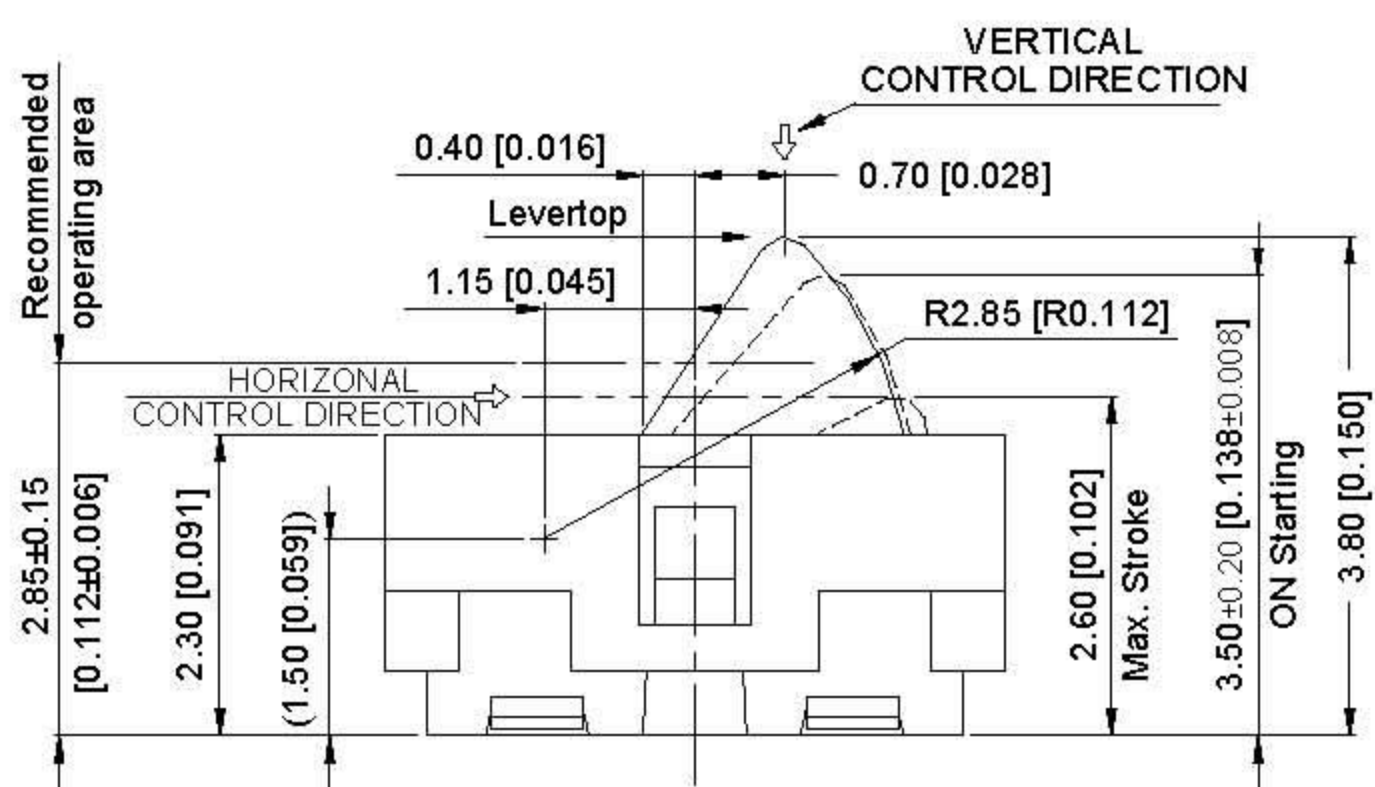
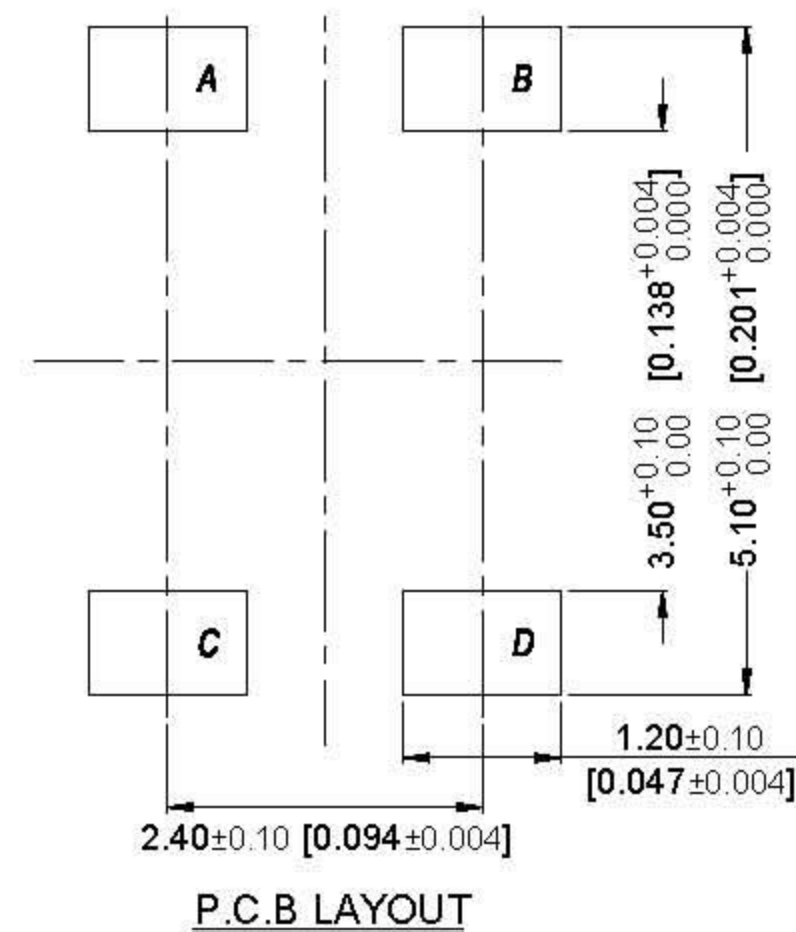
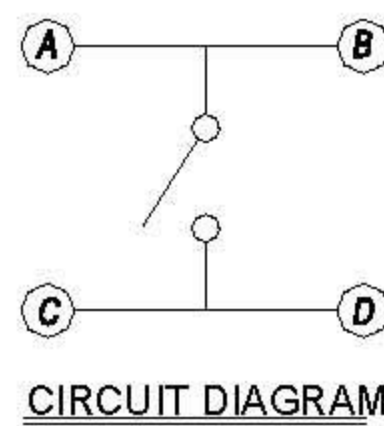
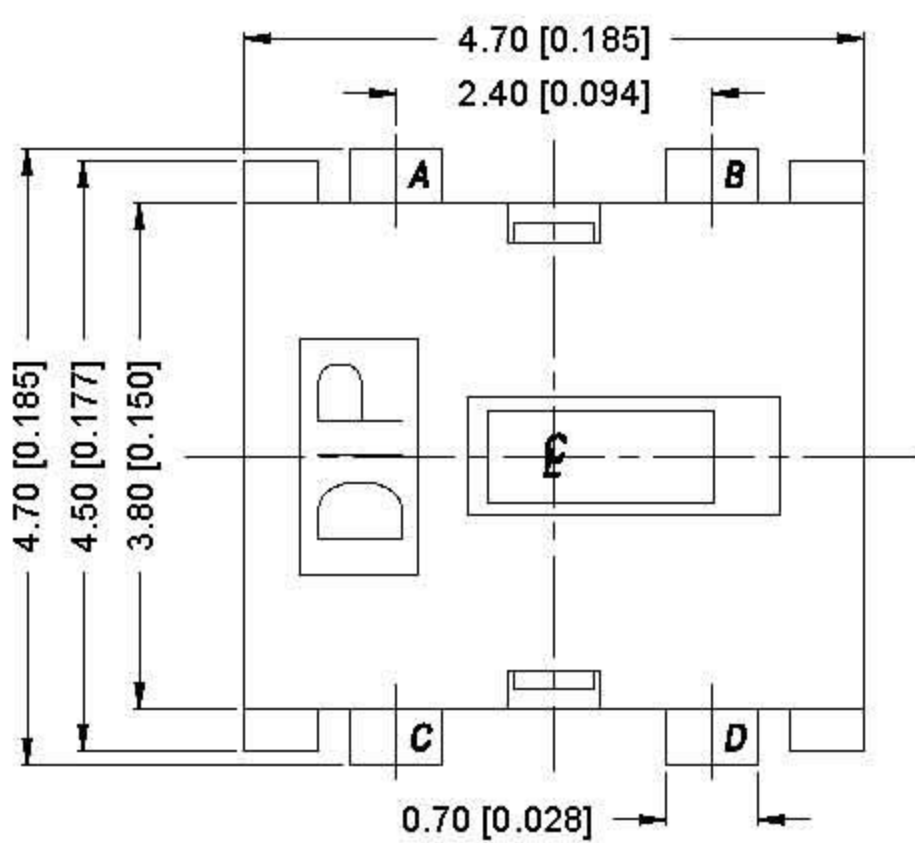

General Tolerance : ±0.2mm

ATE-1C

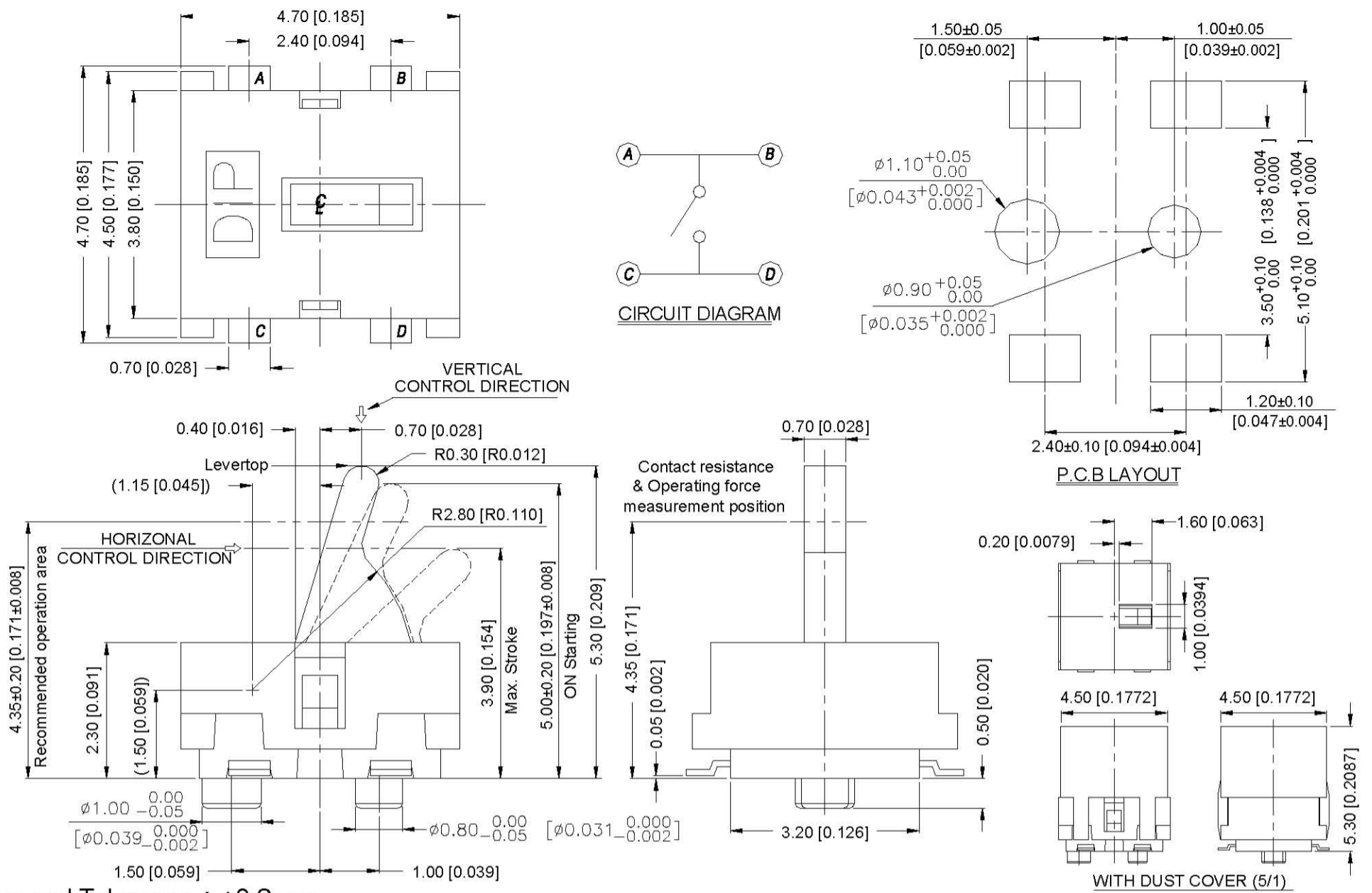

General Tolerance : ±0.2mm

ATE-2C

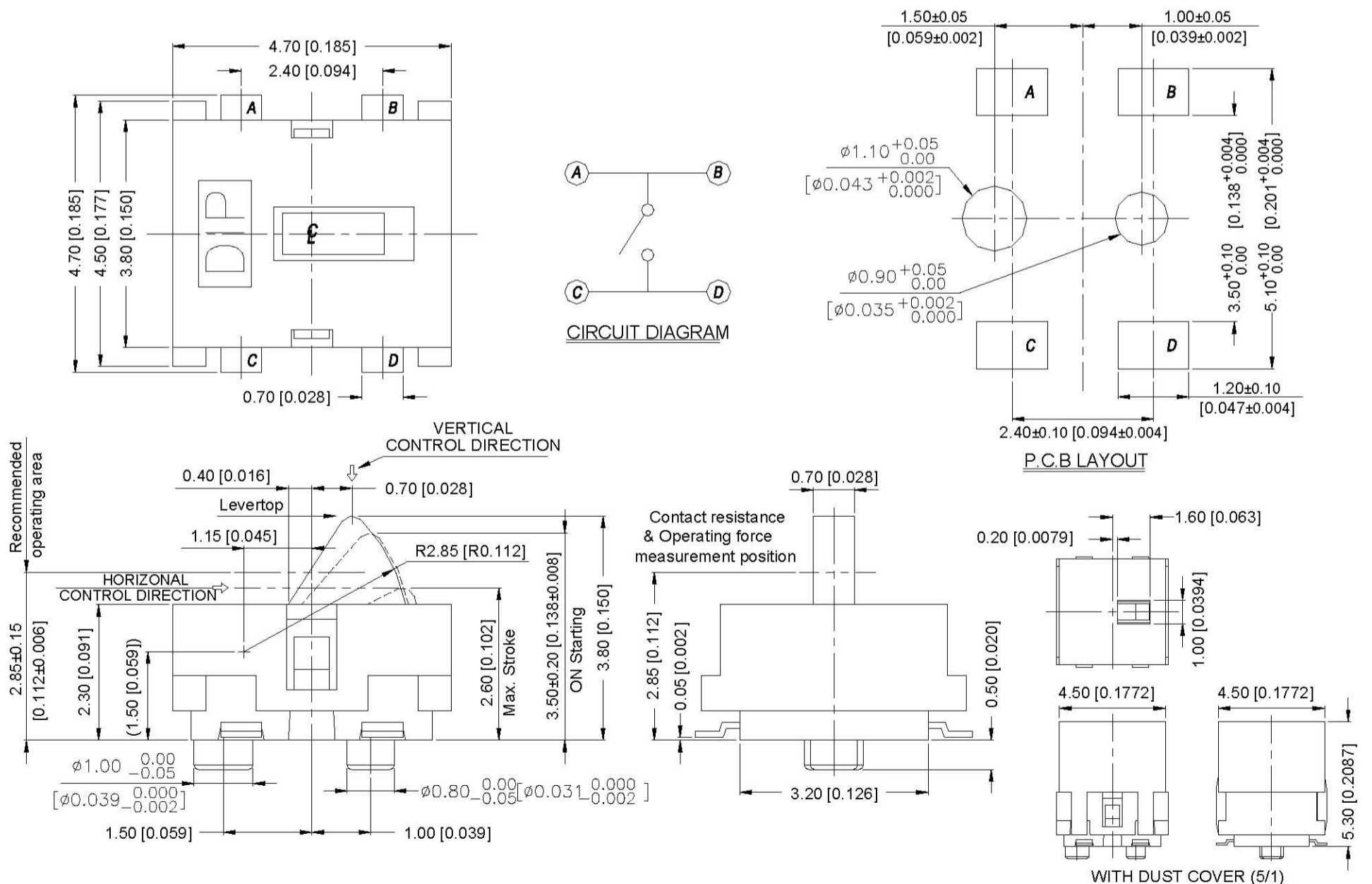

General Tolerance : ±0.2mm

HOW TO ORDER

ATE - - V -

Package :
T/R=Tape & Reel
V=Lead Free Solderable
K=Cover
C=With Post
=Without Post
Stem Height :
1=5.30 mm
2=3.80 mm

DETECTOR SWITCH

SPECIFICATION

△MECHANICAL

Operation Force: 40gf max.

Stork : 3.90mm max. < Stem Height 5.30mm>

2.60mm max. < Stem Height 3.80mm>

Operation Temperature: -10°C to +60°C

Storage Temperature: -20°C to +70°C

△ELECTRICAL

Electrical Life: 100,000 cycles

Rating:1mA , 5VDC

Contact Resistance: 1Ω max.

Insulation Resistance: 100MΩ min. 100V DC

Dielectric Strength: 100VAC / 1 minute

Rate of Operation: 20~25 operation per minute

MATERIAL

△Cover(1) : LCP High-temp Thermoplastic.

Color : Black

△Cover(2) : LCP High-temp Thermoplastic.

Color : Black

△STEM : LCP High-temp Thermoplastic.

Color : Black

△CONTACT : Stainless with silver cladding.

△BASE : PA9T High-temp Thermoplastic

Color : Black

△TERMINAL : Brass, Silver Plating.

SOLDERING PROCESS

△HAND SOLDERING: Use a soldering iron of 30 watts, controlled at 350°C approximately Max 5 seconds while applying.

△REFLOW SOLDERING : When applying reflow soldering, the peak temperature or the reflow oven should be set to 260°C max.

△Temperature Profile :

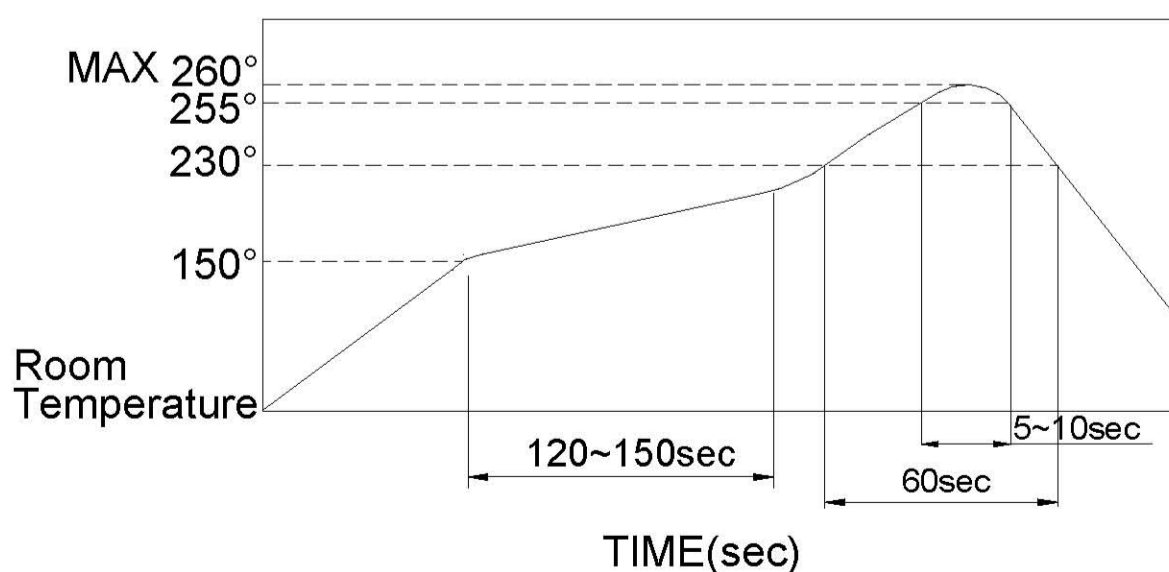

PACKING

Part Number	Number Per Reel
ATE-1□□-T/R	900
ATE-2K-T/R	900
ATE-2CK-T/R	900
ATE-2-T/R	1200
ATE-2C-T/R	1200

ATE-1、2 REEL

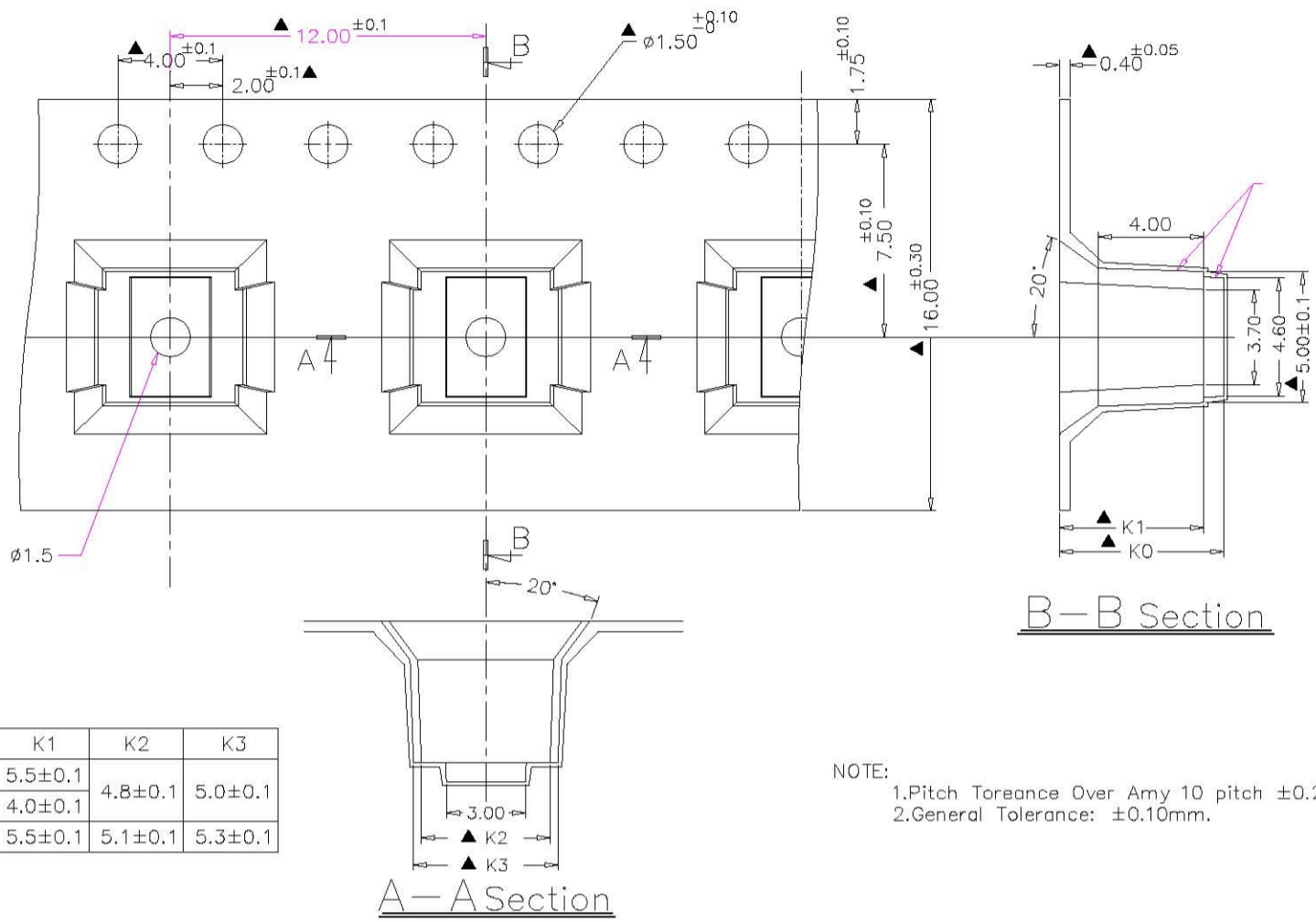

PART NO.	NO.	K0	K1	K2	K3
ATE-1		6.1 ± 0.1	5.5 ± 0.1	4.8 ± 0.1	5.0 ± 0.1
ATE-2		4.6 ± 0.1	4.0 ± 0.1		
ATE-C		6.1 ± 0.1	5.5 ± 0.1	5.1 ± 0.1	5.3 ± 0.1

NOTE:
 1. Pitch Tolerance Over Any 10 pitch ± 0.20mm.
 2. General Tolerance: ± 0.10mm.

General Tolerance : ± 0.1mm